

Pool Setup & Maintenance Guide

Table of Contents

Overview	3
Ball Valve.....	4
Pump.....	7
Cartridge Filter	8
Sand Filter	9
Frog Cycler ®.....	11
AutoPilot ® Salt System	12
Atmospheric Release Valve	13
Test Kit.....	14
Water Chemistry	15
Replace FROG Bac Pac	16
Replace FROG Mineral Cartridge.....	17
AutoPilot ® Salt Generator	18
Cleaning the Strainer Basket (pump)	21
Cleaning the Cartridge Filter.....	22
Cleaning the Sand Filter.....	25
Cleaning the Skimmer Basket.....	26
Vacuuming your pool.....	27
How to Close your Pool (winterizing)	28
How to Open your Pool (Spring opening)	35
Troubleshooting	37

Pool Setup & Maintenance Guide

Pool Setup & Maintenance Guide

Overview

Introduction

This guide was designed to incorporate the basic instructions from the various product manuals that you will receive with your pool and combine them into one quick-reference guide. This guide does not in any way replace or supersede the actual owner's manuals for these products.

Pool Setup & Maintenance Guide

Ball Valve

Introduction

The Ball Valve is the device that controls the flow of water from the pool to the pump. It determines how much of the water flow is from the skimmer and how much is from the floor drain. The valve is shaped like the letter T and it is sometimes referred to as a T-valve.

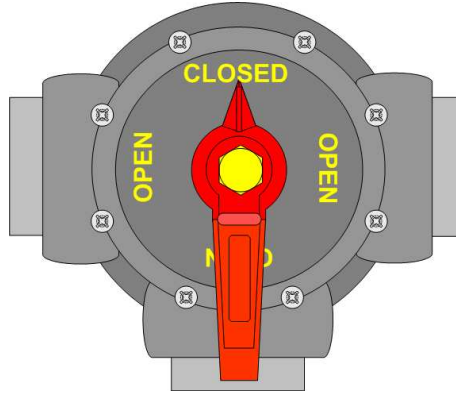

Internal cylinder

Inside is the T-valve, or cylinder, which can rotate to close or open the different ports.

IMPORTANT - To prevent any possible damage turn off the pump before making any adjustments to the ball valve.

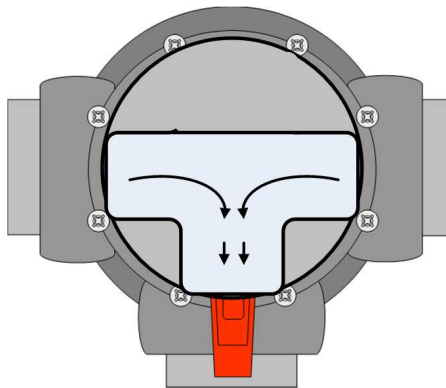

Continued on next page

Pool Setup & Maintenance Guide

Ball Valve, Continued

Open position The handle allows you to rotate the internal cylinder. There are markings showing 'open' and 'closed'. When all the 'open' designations are aligned with the openings (see below), the flow of water is coming half from the skimmer and half from the floor drains and going to the pump.

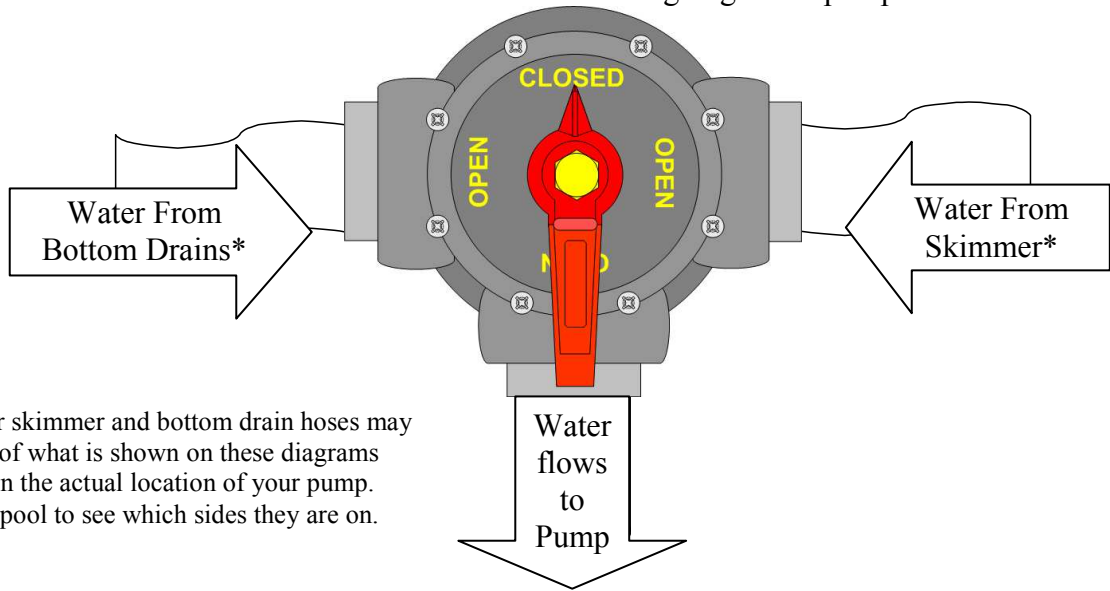

***Note:** Your skimmer and bottom drain hoses may be opposite of what is shown on these diagrams depending on the actual location of your pump. Check your pool to see which sides they are on.

Skimmer only position By turning the handle you can adjust the flow or shut off either the skimmer or bottom drains. For example, you might close the drains to get more suction from the skimmer if you notice a lot of floating debris on top of the water.

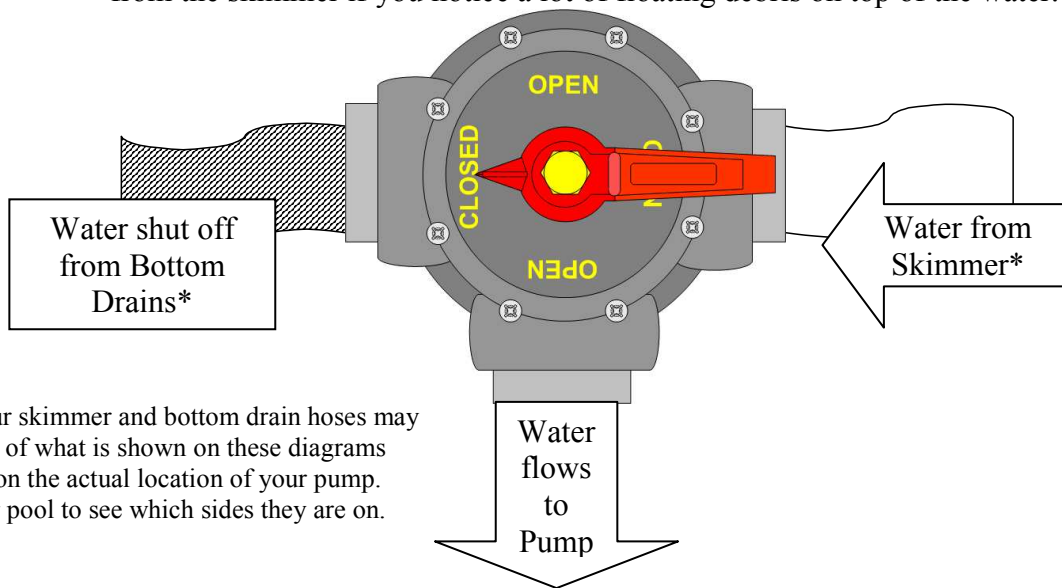

***Note:** Your skimmer and bottom drain hoses may be opposite of what is shown on these diagrams depending on the actual location of your pump. Check your pool to see which sides they are on.

Continued on next page

Pool Setup & Maintenance Guide

Ball Valve, Continued

Bottom drain only position

If not, you might want more drawn from the floor drains to reduce the amount of vacuuming necessary.

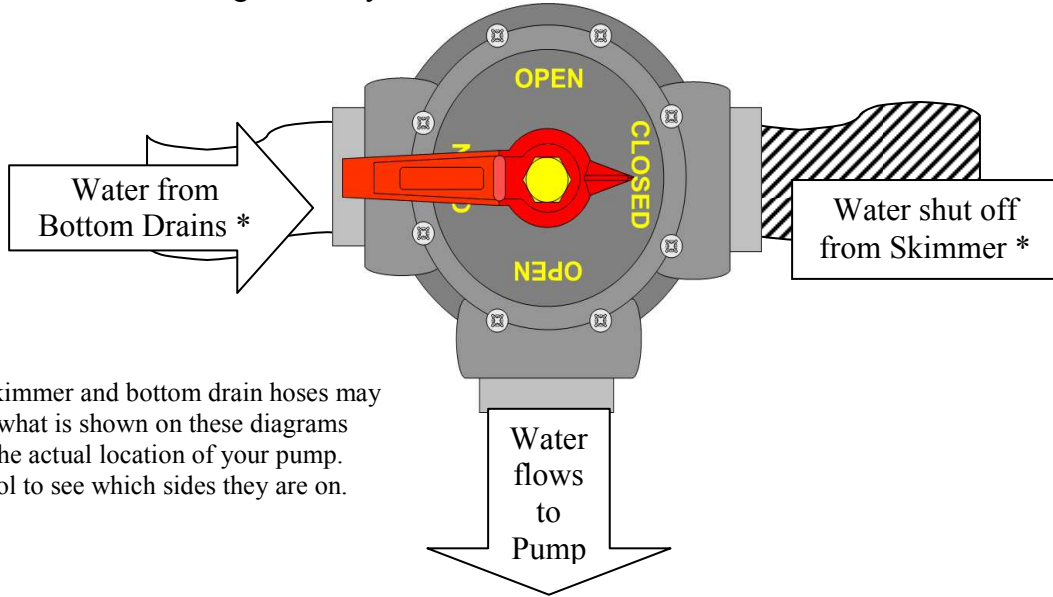

***Note:** Your skimmer and bottom drain hoses may be opposite of what is shown on these diagrams depending on the actual location of your pump. Check your pool to see which sides they are on.

Closed position

You can also shut off the flow going to the pump if you need to service the pump or tank.

IMPORTANT - When needing to turn the handle more than 180°, unscrew the yellow screw and raise the handle past the stop

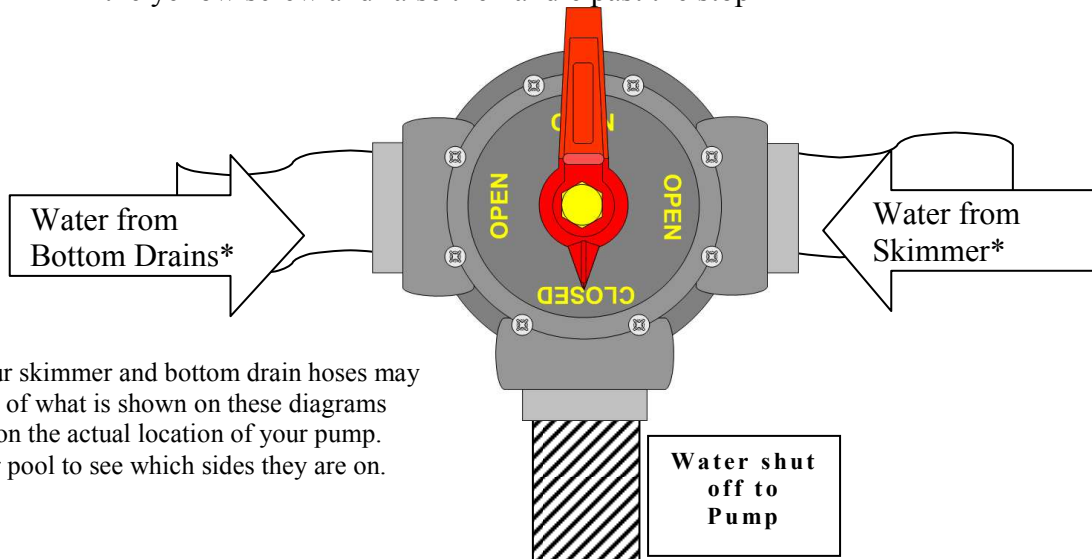

***Note:** Your skimmer and bottom drain hoses may be opposite of what is shown on these diagrams depending on the actual location of your pump. Check your pool to see which sides they are on.

Pool Setup & Maintenance Guide

Pump

Pump

Your pool comes with a 1.5 horsepower pump that pulls water from the pool and strains small objects and particles before they reach the filter and chlorinator.

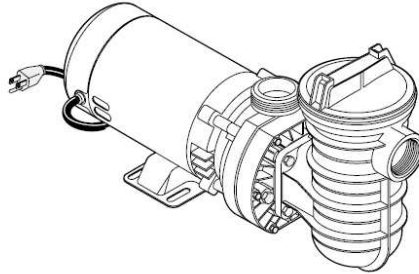

⚠ DANGER HAZARDOUS SUCTION. Pump suction can trap or tear body parts, especially with children. Do not block suction. Small children using pool **MUST ALWAYS** have close adult supervision!

⚠ CAUTION DO NOT OPERATE SYSTEM with water temperatures above 110 degrees F (43 degrees C)

⚠ CAUTION NEVER RUN PUMP DRY. Running pump without water in it may damage seals, causing leakage and flooding. Fill pump with water through the hair and lint strainer lid before starting the pump.

⚠ WARNING DO NOT ADD CHEMICALS to pool directly in the pool skimmer. Adding undiluted chemicals may damage pump and void warranty.

Diagram of Pump

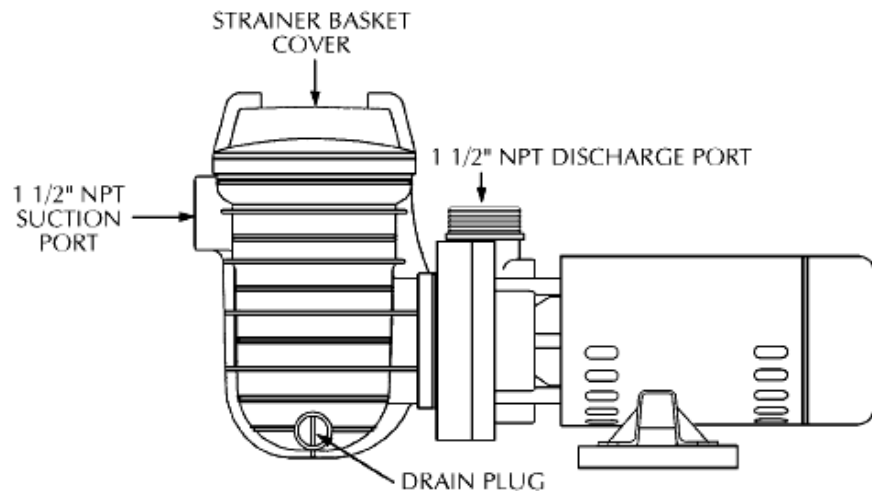

Pool Setup & Maintenance Guide

Cartridge Filter

Cartridge Filter Your pool comes with a cartridge filter.* With this deluxe filter in place and operating correctly, clean water is returned to the pool faster than the pool water is being contaminated.

NOTICE – After pool installation, it typically takes one week of operation to obtain the sparkling clean water that your filter is capable of giving you.

CAUTION - DO NOT OPERATE these filters at more than 50 PSI under any circumstances!

WARNING - HAZARDOUS PRESSURE can cause severe injury or major property damage from tank blow up. Release all pressure and read instructions before working on filter.

Diagram of Cartridge Filter (Fig 1)

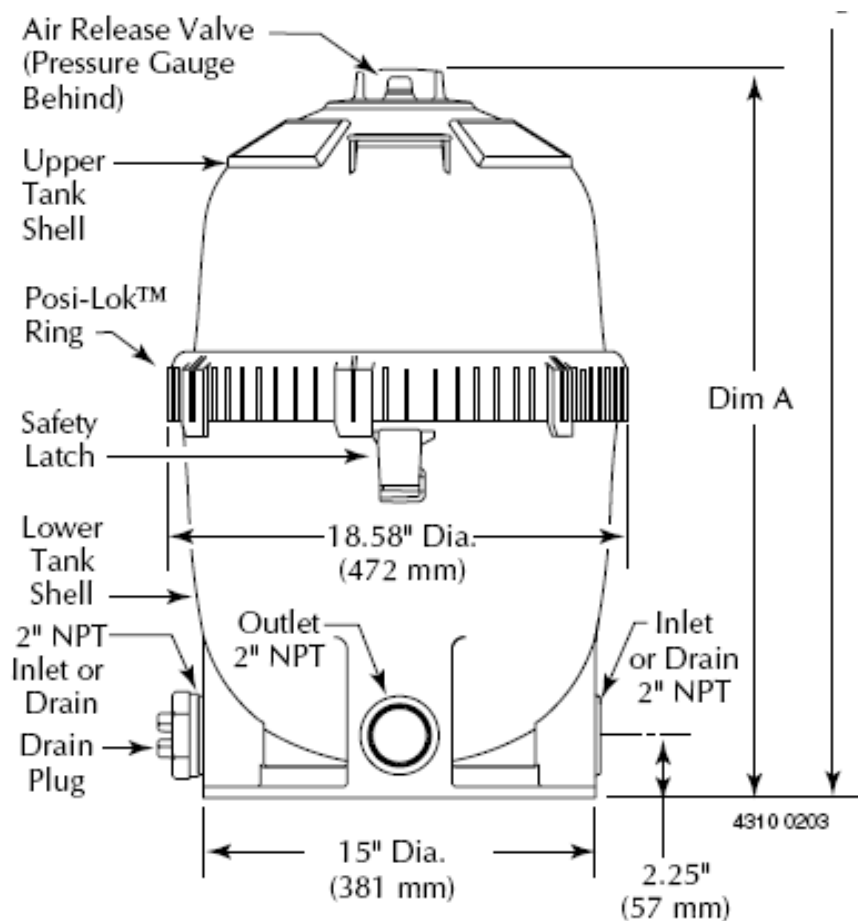

* Note: Your pool is equipped with either a cartridge filter, or a sand filter. Both are outlined in this Pool Guide.

Pool Setup & Maintenance Guide

Sand Filter

Sand Filter

The sand filter uses special filter sand to remove dirt particles from the water. Dirt is collected in the filter by the sand bed as water flows through the filter. Water enters the filter through the valve on top of the filter and is distributed evenly downward across the sand bed. The sand removes the dirt, and the clean water flows through the piping (laterals) at the bottom of the filter, up through the standpipe, back to the valve on top of the filter, where the clean water is returned to the pool through the valve RETURN port.

Diagram of Sand Filter (Fig. 2)

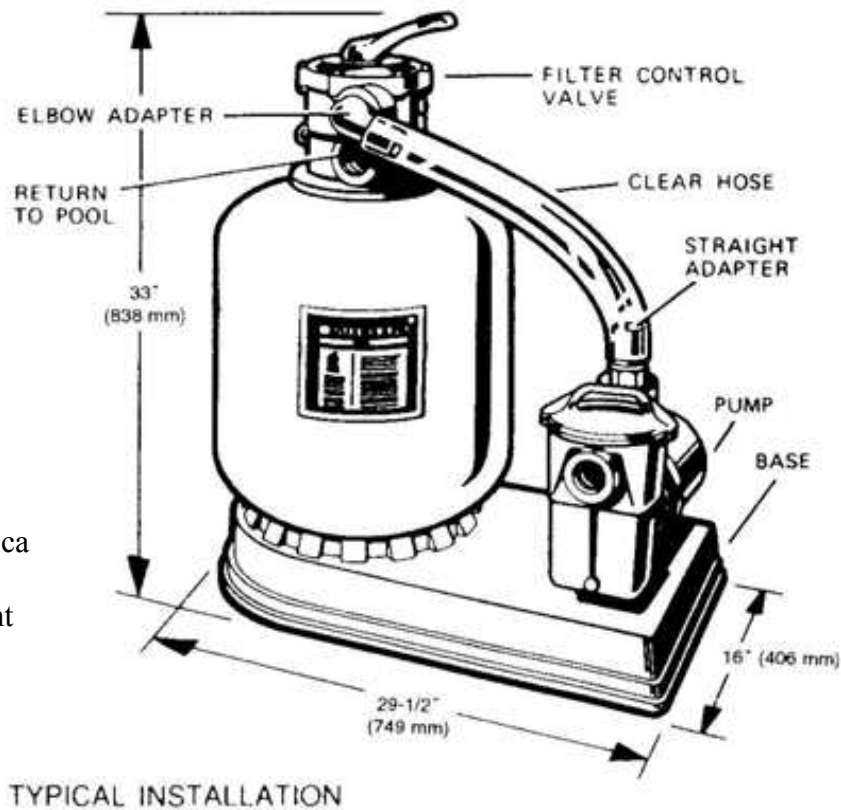

IMPORTANT:

Use #20 standard silica sand having a uniformity coefficient of 1.75 or less

⚠ WARNING

Your filter operates under high pressure. When any part of the circulation system (e.g., clamp, pump, filter, valves, etc.) is serviced, air can enter the system and become pressurized. Pressurized air can cause the lid or control valve to blow off which can result in severe injury, death, or property damage.

Continued on next page

Pool Setup & Maintenance Guide

Sand Filter, Continued

Six-Position Valve (Sand Filter only)

Your six-position valve is designed to provide all the necessary positions required to operate, maintain, trouble shoot and service your filter. **Always depress the handle before turning.**

⚠ CAUTION - To prevent equipment damage and possible injury, always turn off pump before changing valve positions.

⚠ WARNING - Air entering the filter and a valve clamp not closed properly can cause the valve to blow off and could cause severe bodily injury and/or property damage.

Valve Position	Water Flow through Filter
Filter	From pump through valve downward through filter sand bed, up through standpipe to valve RETURN port. For normal filter action and vacuuming pool through filter.
Backwash	From pump through valve, down through standpipe, upward through sand bed, and to valve WASTE port. For cleaning filter by reversing flow.
Rinse	From pump through valve downward through filter sand bed, up through center pipe to valve WASTE port. For start-up cleaning and resetting filter bed after backwashing.
Waste	From pump through valve bypassing filter going to WASTE port. For vacuuming directly to waste, lowering pool level, or draining pool.
Closed	NO FLOW – Always leave pump off while valve is in the “Closed” position. NOTICE - DO NOT USE THIS SETTING WITH PUMP OPERATING.
Recirculate	From pump, through valve, bypassing filter and going to RETURN port. For circulating water without going through filter.
Winterize	See Winterization of Sand Filter

Return and Waste Ports (Fig. 3)

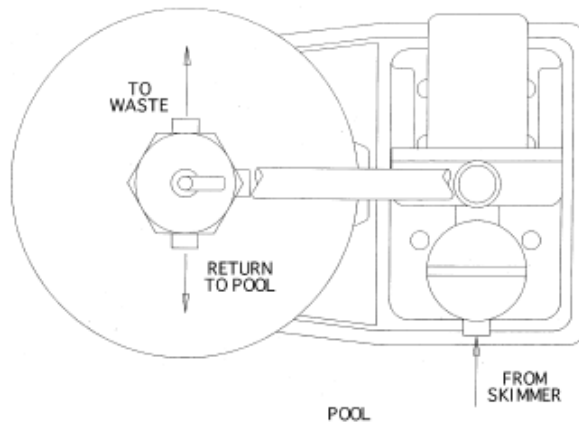

Pool Setup & Maintenance Guide

Frog Cyclor ®

About the Frog Cyclor ®

With a FROG ® auto-chlorinator your pool water will look and feel better without a lot of work or a lot of chlorine. The minerals destroy bacteria and help keep the pH in a safe range without monitoring while reducing chlorine use. The end result is softer water that has an added sparkle.

Using your test kit (included with maintenance package) and your FROG ® Cyclor you will be able to maintain the ideal water balance chemistry.

⚠ WARNING – Avoid sparks, open flame or smoking when handling the Bac Pac.



Pool Setup & Maintenance Guide

AutoPilot® Salt System

About your Salt System

Used in place of an auto-chlorinator, the Pool Pilot Digital® is an advanced unit. It features:

- A digital read-out of pool water temperature, current salt level, purifier production level, soft reverse cell cleaning cycle and boost cycle.
 - The easy to read digital readout on this in-line unit even tells you how much salt to add should it run low.
 - The Pool Pilot Digital has a patented temperature compensation feature that actually adjusts chlorine production according to the demands of the water temperature and operates in water temperatures up to 104°.
 - It can purify pools up to 50,000 gallons and has a built-in time clock to control your pool pump
-



Pool Setup & Maintenance Guide

Atmospheric Release Valve

About the Atmospheric Release Valve (ARV)

The ARV is a safety feature that prevents continuous suction from the bottom drain of the pool when the drain is blocked*. As water is sucked from the bottom drain, it flows directly through the ARV before going to the filter. If the bottom drain is blocked, water stops flowing into the ARV, and it draws in air from the vertical safety pipe which is sent to the pump. When air is drawn into the pump, it automatically shuts off. This stops the suction, releasing whatever was blocking the bottom drain within fractions of a second.

***Note:** Your skimmer and bottom drain hoses may be opposite of what is shown on these diagrams depending on the actual location of your pump. Check your pool to see which sides they are on.

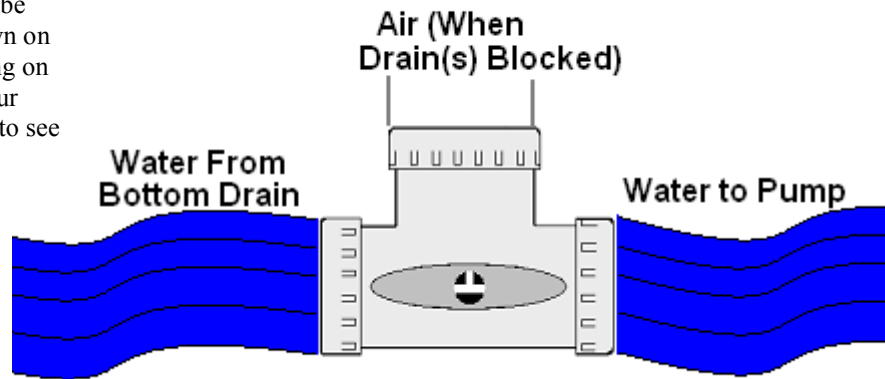

*On pools with dual bottom drains, if a drain is blocked, all suction diverts to the other drain. The ARV will only activate if both drains are blocked.

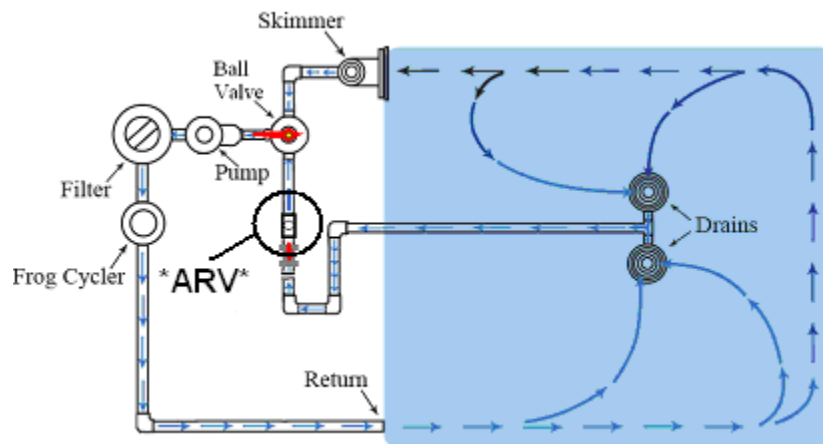

Pool Setup & Maintenance Guide

Test Kit

How to Use the Test Kit

A test kit enables you to test two important factors:

- combined chlorine level
- and pH level.

To keep your pool at its best, test each end of the pool at least twice a week.



Step	Action
1	Remove a test strip from the bottle and replace cap tightly.
2	Hold the strip underwater (1 foot below surface) for 1 second and remove. NOTICE – DO NOT shake excess from the test strip
3	Hold the strip level, pad side up, for 15 seconds.
4	Compare the pH pad to the color patches on the label. <ul style="list-style-type: none"> • The pH pad will turn a shade of red-orange. • The ideal range for pH is between 7.2 to 7.6. • Write down the result.
5	Compare the Free Chlorine pad to the color patches on the label. <ul style="list-style-type: none"> • The Free Chlorine pad will turn a shade of pale-purple. • The ideal range for Free Chlorine is between 1 to 3 ppm. • Write down the result.
6	Compare the Total Alkalinity pad to the color patches on the label. <ul style="list-style-type: none"> • The alkalinity pad will turn a shade of green. • The ideal range for Total Alkalinity is between 80-120 ppm. • Write down the result.
7	Compare the Stabilizer pad to the color patches on the label. <ul style="list-style-type: none"> • The Stabilizer pad will turn a shade of brown to purple. • The ideal range for Total Stabilizer is between 30-100 ppm. • Write down the result.
8	Then using your test kit, find the FROG dial setting that works best for you. Once you have determined the dial setting that works best make a note of it, or using a permanent marker, make a line right on the FROG canister.

Pool Setup & Maintenance Guide

Water Chemistry

Adding Chemicals

In general, chlorine and other chemicals should be added directly to the pool water with the filter running. When handling and administering pool chemicals, read the instructions carefully and follow the manufacturer’s directions.

WARNINGS

- **ALWAYS** add chemicals to water, NOT water to chemicals
- **NEVER** mix chemicals – add them to the pool separately.
- **NEVER** add chlorine products in your skimmer.

Stabilizer – Chemically, a stabilizer (also called conditioner) is Cyan Uric acid. It slows down the degradation of chlorine in the water by sunlight. Too much does not slow down chlorine activity or effectiveness. Adding stabilizer will also prevent “chlorine burn off” which is the deterioration of chlorine from extreme heat. Minimum level is 10 ppm. The ideal level of stabilizer is 25 ppm.

pH Importance – A low pH indicates acidic water and a high pH indicates alkaline (basic) water. pH should always be adjusted to the proper range before the addition of chlorine or other chemicals otherwise it will seriously affect their performance.

Symptom	Cause	Solutions
Cloudy / Milky water (no green slime)	A. pH or Alkalinity problem B. Low Sanitizer level C. Calcium based chlorine D. Suspended particles	A. Test & balance with recommended products. B. Shock pool & check Chlorine level C. Discontinue use and start with stabilized chlorine. D. Clean filter. Continue to filter. Keep water balanced.
Brown or Rusty water (not slimy)	Iron or Mineral problem	Add mineral remover, keep filter clean.
Rapid Loss of Chlorine	A. Insufficient Stabilizer (cyanuric acid) B. Large bather load	A. Add Stabilizer B. Shock pool & check Chlorine level
Green / Slimy water	Algae	A. Shock pool & check Chlorine level B. Add Algaecide C. Adjust pH to 7.2 – 7.6 by adding pH products
Spots on Liner A. Brown B. White	A. Low Alkalinity B. Improper use of Chlorine	A. Test and add Alkalinity increaser B. Read label and follow directions of use
Strong Chlorine smell	Chlorine efficiency depleted	A. Shock pool & check Chlorine level



Pool Setup & Maintenance Guide

Replace FROG Bac Pac

How to Replace FROG Bac Pac

Not required with salt system

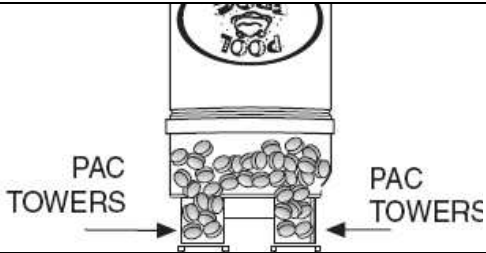
The FROG® Bac Pac must be replaced every 2-3 weeks depending on use.

Step	Action
1	Turn off the pump.
2	Put the Ball valve in the “ closed position ”
3	Set Frog Dial to 0 (Pack Removal)
4	Unscrew and remove the top of FROG Cyclor canister.
5	Remove Bac Pac.
6	Remove Bac Pac colored caps, grab on to the lip of one cap with a pair of pliers and pull up until cap releases. Repeat the process for the other cap. ⚠ WARNING Avoid sparks, open flame or smoking when handling the Bac Pac.
7	Turn Bac Pac over and shake slightly until chlorine tablets fall into tower areas. 
8	<div style="display: flex; align-items: center;"> <div style="margin-right: 20px;">  </div> <div> <p>Line up the small leg of the Bac Pac with the small opening in the Mineral Reservoir and the large leg with the large opening.</p> </div> </div> <ul style="list-style-type: none"> • Lower Bac Pac into Mineral Reservoir until secure.
9	Replace cap by hand only. DO NOT OVER TIGHTEN ⚠ CAUTION DO NOT USE CAP TOOL TO TIGHTEN CAP. Use for removal only.
10	Set Frog Dial back to normal operating level
11	Put the Ball valve in the “ open position ”
12	Start pump to purge air from the system.

Pool Setup & Maintenance Guide

Replace FROG Mineral Cartridge

How to Replace FROG Mineral Cartridges

Not required with salt system

The POOL FROG® mineral reservoir must be replaced every 6 months or after one pool season whichever is shorter.

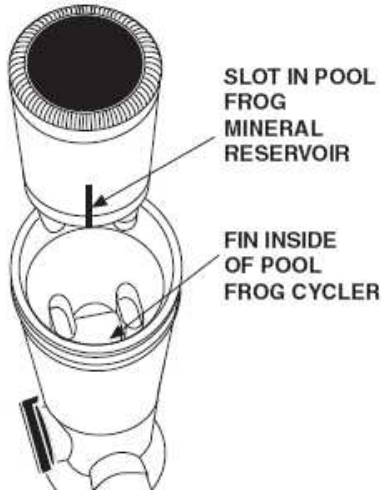
Step	Action
1	Turn off the pump.
2	Put the Ball valve in the “ closed position ”
3	Set Frog Dial to 0 (Pack Removal)
4	Unscrew and remove the top of FROG Cyclor canister.
5	Remove Bac Pac and Mineral Reservoir.
6	<p>Replace with new FROG ® Mineral Reservoir. Be sure to line up the slot in the reservoir with the fin inside of the canister as shown below</p> <p>Figure 1</p>  <p>The diagram, labeled Figure 1, shows two cylindrical components. The top component is the 'SLOT IN POOL FROG MINERAL RESERVOIR' and the bottom component is the 'FIN INSIDE OF POOL FROG CYCLOR'. Arrows indicate that the slot in the reservoir must be aligned with the fin inside the cyclor canister.</p>
7	Lower Bac Pac into Mineral Reservoir until secure. Be sure to line up the small leg of the Bac Pac with the small opening in the Mineral Reservoir and the large leg with the large opening
8	<p>Replace cap by hand only. DO NOT OVER TIGHTEN</p> <p>⚠ CAUTION DO NOT USE CAP TOOL TO TIGHTEN CAP. Use for removal only.</p>
9	Set Frog Dial back to normal operating level.
10	Put the Ball valve in the “ open position ”
11	Start pump to purge air from the system.

Pool Setup & Maintenance Guide

AutoPilot® Salt Generator

Initial Startup For initial startup programming of the AutoPilot® Digital Pool Pilot, please follow the steps outlined below.

NOTICE - DO NOT ADD SALT before completing these steps.

Step	Action
1	Start with a balanced and clean pool.
2	<ul style="list-style-type: none">• Press MENU button and use the arrows (triangles) to scroll to INSTALLER MENU.• Press and HOLD the SELECT button for about 13 seconds.
3	<ul style="list-style-type: none">• In INSTALLER MENU, scroll to SET POOL VOLUME and press SELECT.• Using the arrows, identify the correct pool water volume in gallons (within 500 gallons)• Press SELECT.
4	<ul style="list-style-type: none">• Scroll to SET PUMP CONTROL option and press SELECT, Choose one of the following settings:<ul style="list-style-type: none">• External Timer (use this if you are using an external timer)• <i>Two Speed Pump</i> (DO NOT USE)• One Speed Pump (use this if the POOL PILOT is wired to be the pump timer)• Press SELECT
5	<ul style="list-style-type: none">• Scroll to find SET CELL TYPE and press SELECT• Use arrows to find your cell type. (factory setting is SC-48)• Press SELECT.
6	<ul style="list-style-type: none">• Scroll to EXIT MENU MODE and press SELECT.• Unit will return to normal operating mode.

Continued on next page

Pool Setup & Maintenance Guide

AutoPilot® Salt Generator, Continued

Program timer If POOL PILOT will be the pump timer, then follow these steps to set timer.

Step	Action						
1	<ul style="list-style-type: none"> • Press MENU button and use the arrows (triangles) to scroll to OWNER OPTIONS. • Press SELECT. 						
2	Use the arrows (triangles) to scroll and SELECT to choose function: (<i>*recommended</i>) <ul style="list-style-type: none"> • English/Metric: displays volume in <i>*gallons</i> or cubic meters; salt additions in <i>*lbs</i> or kg • Temperature Units: displays the water temperature in <i>*Fahrenheit</i> or Celsius • 12/24-hour Time: displays the current time in <i>*12-hour Time</i> or 24-hour Time units • Set Time of Day: sets current time: Set Hours; Set Minutes • Pump Program 1 (see step 3) • Pump Program 2 (see step 3) 						
3	Use the arrows (triangles) to choose Pump Program 1 and press SELECT. <ul style="list-style-type: none"> • Press ^ (up-arrow) to program Pump ON at Set Hours “12”:00 P Pump ON at Set Mins 12:“00” P Pump OFF at Set Hours “12”:00 P Pump OFF at Set Mins 12:“00” P <table border="1" style="width: 100%; border-collapse: collapse;"> <thead> <tr> <th style="text-align: center;">If</th> <th style="text-align: center;">Then</th> </tr> </thead> <tbody> <tr> <td style="padding: 5px;">You want to run pump for 12 hrs</td> <td style="padding: 5px;"> <ul style="list-style-type: none"> • Set Pump ON at 08:00 A • Set Pump OFF at 08:00 P </td> </tr> <tr> <td style="padding: 5px;">You want to run pump for 24 hrs</td> <td style="padding: 5px;"> <ul style="list-style-type: none"> • Set Pump ON at 01:00 A • Set Pump OFF at 12:59 A </td> </tr> </tbody> </table>	If	Then	You want to run pump for 12 hrs	<ul style="list-style-type: none"> • Set Pump ON at 08:00 A • Set Pump OFF at 08:00 P 	You want to run pump for 24 hrs	<ul style="list-style-type: none"> • Set Pump ON at 01:00 A • Set Pump OFF at 12:59 A
If	Then						
You want to run pump for 12 hrs	<ul style="list-style-type: none"> • Set Pump ON at 08:00 A • Set Pump OFF at 08:00 P 						
You want to run pump for 24 hrs	<ul style="list-style-type: none"> • Set Pump ON at 01:00 A • Set Pump OFF at 12:59 A 						
4	After setting Pump Program 1 it will cycle to Pump Program 2. <ul style="list-style-type: none"> • Press v (down-arrow) to DELETE program • Press BACK to return to MAIN MENU. 						

Continued on next page

Pool Setup & Maintenance Guide

AutoPilot® Salt Generator, Continued

Adding Salt

Follow the steps below to add salt. The manufacturer suggests 99.5% PURE WATER SOFTENER SALT – but your local pool supply company should have salt that will work just as well.

Should you have any problems or questions about the AutoPilot® Salt Generator call **1 800 786-7751**.

Step	Action						
1	Put the Ball valve in the “ Bottom Drain only position ”						
2	Dump salt in deep end or end farthest from skimmer. <ul style="list-style-type: none"> • As a general rule you should add <u>50 lbs of salt per 2000 gallons</u> of water to get to 3000 ppm (parts per million). • Most water has some salt content already so <u>it is recommended to add only about 75% of the salt</u> at this step. If any remaining salt needs to be added the unit will tell you. (step 5) 						
3	Brush salt toward bottom drains.						
4	The next day test the pool water using salt test strips to find your water’s salt level (ppm).						
5	Press the MENU button and the option to “TEST POOL PILOT” will come up. Press SELECT. The unit will show you the SALT LEVEL in ppm. <table border="1" style="width: 100%; margin-top: 5px;"> <thead> <tr> <th style="text-align: center;">If</th> <th style="text-align: center;">Then</th> </tr> </thead> <tbody> <tr> <td>SALT LEVEL (ppm) matches results of test strip.</td> <td>You are done. The unit will tell you how much salt to add if needed.</td> </tr> <tr> <td>SALT LEVEL (ppm) does not match</td> <td>Go to <u>Calibrate Salt</u>.</td> </tr> </tbody> </table>	If	Then	SALT LEVEL (ppm) matches results of test strip.	You are done. The unit will tell you how much salt to add if needed.	SALT LEVEL (ppm) does not match	Go to <u>Calibrate Salt</u> .
If	Then						
SALT LEVEL (ppm) matches results of test strip.	You are done. The unit will tell you how much salt to add if needed.						
SALT LEVEL (ppm) does not match	Go to <u>Calibrate Salt</u> .						
6	Once salt level is calibrated and your water tests at 3000 ppm of salt, you can return the Ball valve to the “ Open position ”						

Calibrate Salt

Follow the steps below to calibrate the salt level with the unit.

Step	Action
1	Press MENU, scroll to MAINTENANCE MENU and press SELECT.
2	Scroll to CALIBRATE SALT and press SELECT.
3	Use the arrows to adjust the salt level to results from test kit. <ul style="list-style-type: none"> • It takes a while for the unit to adjust, when it finishes you’ll be able to exit the menu.

Pool Setup & Maintenance Guide

Cleaning the Strainer Basket (pump)

Cleaning the Strainer Basket

Follow the steps below to check the strainer basket for debris. This should be checked once a week.

Step	Action
1	Shut off pump.
2	Make sure the Ball valve is in the “ closed position ”.
3	Unscrew strainer basket cover and remove.
4	Turn strainer basket ¼ turn to remove it.
5	Clean all debris out of strainer basket and check O-Ring.
6	Replace and twist ¼ turn.
7	Replace Cover.
8	Make sure the Ball valve is in the “ open position ”.
9	Start pump to purge air from the system.

Figure 2

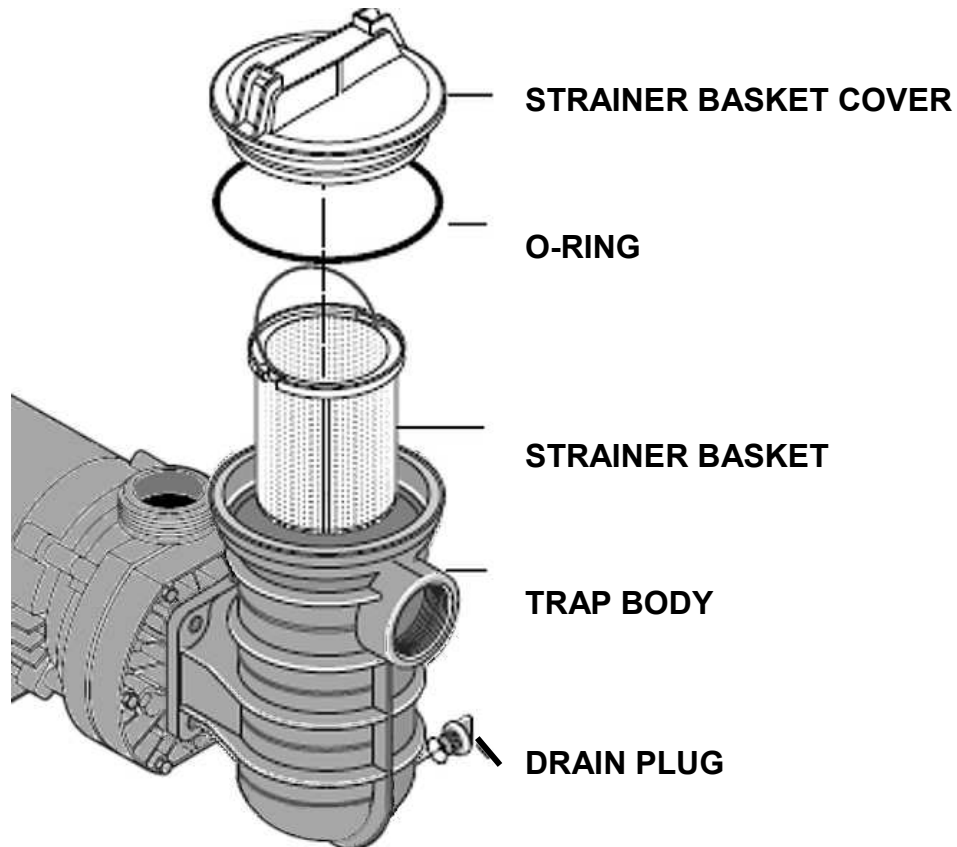

Pool Setup & Maintenance Guide

Cleaning the Cartridge Filter

Cleaning the Cartridge Filter

IF YOUR POOL IS EQUIPPED WITH A CARTRIDGE FILTER:
 The first time you turn on your pump check the reading on the pressure gauge on the filter and write it down for future reference.

- This is your pool's normal operating pressure.

The filter module should be cleaned when the pressure gauge reading increases 10 PSI over the normal operating pressure

Step	Action
1	Turn off the pump.
2	Put the ball valve in the “ closed position ”
3	Open air release valve on top of filter. (see Fig 3)
	NOTICE: Open the air bleed valve and bleed all air from the filter each time the pump is stopped and restarted.
4	Remove the drain plug and drain all water from the filter.
5	Push button to release locking ring and unscrew. (see Fig 4)
6	Use fin on ring to pry open top of filter. (see Fig 5 -6)

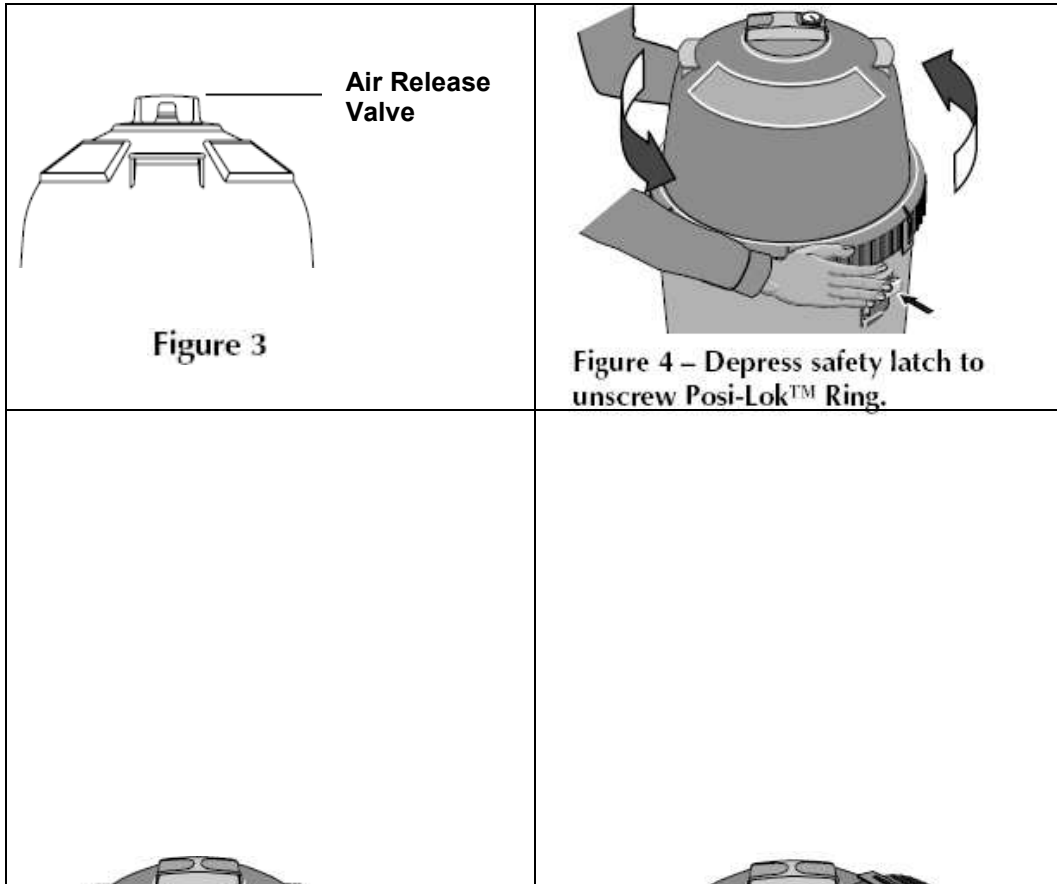

Figure 3

Figure 4 – Depress safety latch to unscrew Posi-Lok™ Ring.

Continued on next page

Pool Setup & Maintenance Guide

Cleaning the Cartridge Filter, Continued

Step	Action
7	With a hose equipped with a soft flow nozzle, wash as much dirt as possible off of the cartridge module while it is still in the tank. NOTICE: DO NOT use solvents to clean the filter; solvents may damage plastic components in the system.
8	Allow tank to drain completely and flush foreign material from inside of tank.
9	Once inside of tank is clean, lift out the module and hose it down thoroughly. Spray the entire module surface. Allow module to drain completely.
10	Inspect the module, if necessary, repeat the washing operation. If the module is damaged, replace it.
11	Inspect and clean the air bleed filter at top of module. (see Fig 7)
12	Replace cartridge filter and making sure to line up port on the cartridge with the check valve. (see Fig 8)

Continued on next page

Figure 7

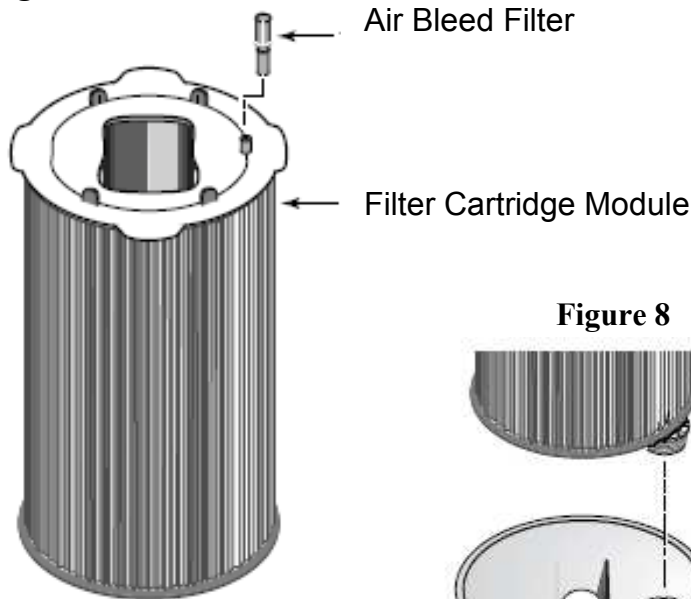
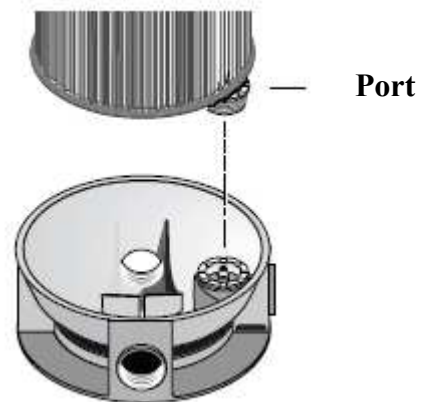

Figure 8



Pool Setup & Maintenance Guide

Cleaning the Cartridge Filter, Continued

Step	Action
13	Push down on the top of the filter to fully seat the upper tank shell.
14	Rotate the Posi-Lok™ ring <u>clockwise</u> until it “clicks” past the safety latch. (see Fig 9)
15	Put the ball valve in the “ open position ”
16	Start pump to purge air from the system.
17	When steady stream of water comes from air release valve close the valve.
18	Check the reading on the pressure gauge to ensure that your pressure has dropped to its normal levels

Figure 9

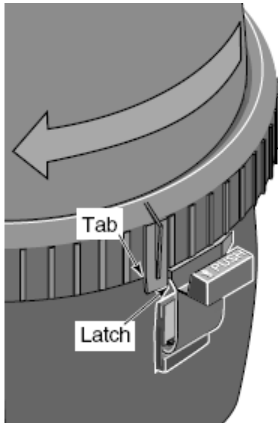

⚠ CAUTION Lubricate O-ring only with the silicone grease provided or equivalent, as other lubricants may cause the ring to swell. **DO NOT** lubricate Posi-Lok™ ring or threads on lower tank shell as this may collect grit and make removal difficult.

NOTICE The ring may feel slightly loose the first time you are putting it on, but it will tighten up when pump is on and filter is under pressure.

Pool Setup & Maintenance Guide

Cleaning the Sand Filter

Cleaning the Sand Filter (Backwashing)

IF YOUR POOL IS EQUIPPED WITH A SAND FILTER:

The first time you turn on your pump check the reading on the pressure gauge on the filter and write it down for future reference.

- This is your pool's normal operating pressure.

The filter module should be cleaned when the pressure gauge reading increases 10 PSI over the normal operating pressure.

NOTICE - It is important NOT to backwash the filter solely on a timed basis such as every two days. It is also important to note that backwashing too frequently actually causes poor filtration.

Step	Action
1	Turn off the pump.
2	Ensure lines are open and clear, and set control valve to "Backwash" position.
3	Stand clear of the filter and start the pump.
4	Backwash filter for approximately 3-5 minutes or until backwash water is clean.
5	Turn off pump. Set control valve back to "Rinse" position.
6	Stand clear of the filter and start pump.
7	Rinse filter for approximately 3-5 minutes.
8	Turn off pump. Set control valve back to "Filter" position.
9	Stand clear of the filter and start pump.
10	The filter has now started its filtering cycle. Check that water is returning to the pool and take note of the filter pressure. NOTICE: The filter pressure in step 9 above should not exceed the pressure originally observed on the filter when it was initially started. If after backwashing the pressure is 4-6 PSI above the start condition, it is an indication to change the sand in the filter.

Pool Setup & Maintenance Guide

Cleaning the Skimmer Basket

Cleaning the Skimmer Basket

Follow the steps below to clean the skimmer basket. This should be done on a regular basis and as necessary.

Step	Action
1	Turn off the pump.
2	Gently pull the skimmer door forward and pull out the skimmer basket.
3	Shake out debris and spray with hose to clean.
4	Replace skimmer basket
5	Restart pump.

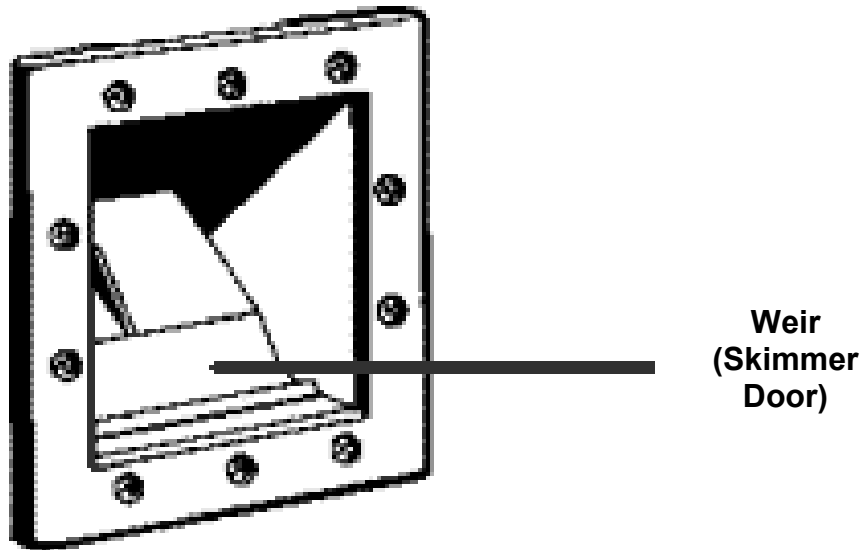

Pool Setup & Maintenance Guide

Vacuuming your pool

How to Vacuum your Pool

Your pool vacuum works very much like a household vacuum, but uses water instead of air. For this reason, care must be taken not to let air get in the system as this would weaken or halt the suction.

Step	Action
1	Clean the Pump Strainer, the Filter (Cartridge or Sand), and the Skimmer basket. (see previous instructions)
2	Gather the necessary materials: Vacuum head, Vacuum pole, Vacuum hose, Skim vac attachment.
3	Attach the vacuum head to the vacuum pole.
4	Attach the vacuum hose to the vacuum head
5	Turn off the Pump.
6	Put the ball valve in the “ skimmer only position ”
7	Remove the door from Skimmer.
8	Place Skim vac attachment in the skimmer over the basket
9	Turn on the Pump.
10	Submerge the vacuum head under the water and fill the hose by placing the open end of the hose in front of the water return valve.
11	When all the air is out of the hose, attach the end to the skim vac attachment, keeping the hose underwater so you don’t let any air into the hose. The vacuum is now primed and ready to clean.
12	<p>Press down firmly as you vacuum and move the head <u>slowly</u> across the bottom.</p> <p>NOTE – While it may seem that vacuuming at a fast pace appears to do the job equally well, this actually creates waves, which will lift dirt up and suspend it in the water. This dirt will eventually settle back down to the bottom.</p> <ul style="list-style-type: none"> • If the pool is very dirty and suction seems to decrease after vacuuming for a while, it could be a sign that the filter needs cleaning again
14	<p>After vacuuming is completed, turn off Pump and remove skim vac attachment from skimmer. Replace skimmer door.</p> <p>⚠ CAUTION DO NOT pull the skim vac out of the skimmer with the pump turned on, this will cause damage to the skimmer.</p>
15	Clean the Pump Strainer and the Skimmer basket again.
16	Put the ball valve in the “ Bottom Drain only position ”
17	Turn on the Pump.
18	Let the pool run on bottom drain only for a few hours before returning it to the “ open position ”

Pool Setup & Maintenance Guide

How to Close your Pool (winterizing)

Pool Preparation

To begin the pool winterizing procedure, follow these simple steps. Start with clean, clear water (vacuum if necessary). Make sure there are no liner leaks!

NOTE - A 24' round pool has 13,500 gallons and usually a winterizing kit will handle up to 12,000 gallons

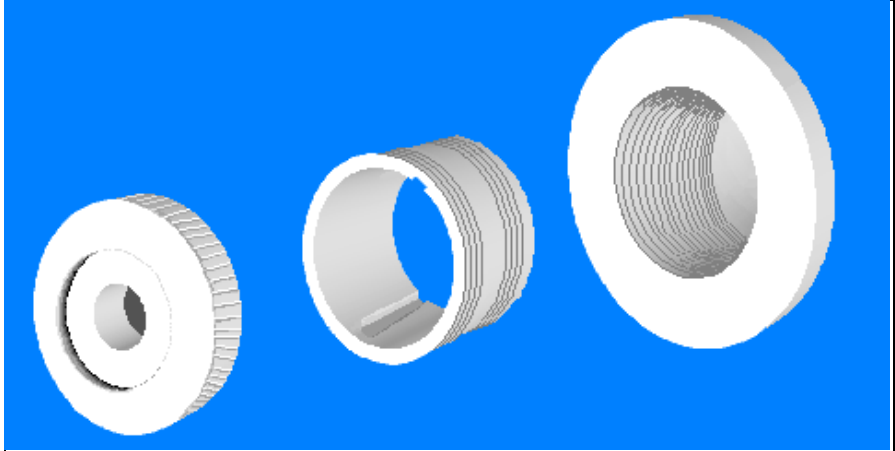
Step	Action
1	Remove in-pool ladder by loosening the set screws in the ladder flanges (cups on deck).
2	<p>Remove the “eye-ball” and “sleeve” from the return port. This unscrews counterclockwise (see below)</p> <p>If you have a jet air attachment or fountain, you will remove this instead of the eyeball)</p> <div style="text-align: center;">  </div> <div style="display: flex; justify-content: space-around; text-align: center;"> <div>EYE-BALL</div> <div>SLEEVE</div> <div>RETURN PORT</div> </div>
3	Remove skimmer basket.
4	Clean vinyl with Tile & Vinyl Cleaner.
5	Add winter chemicals. Usually shock and winter algaecide.
6	<p>Continue to run pool filter to thoroughly dissolve chemicals for 6-8 hours.</p> <p>⚠ CAUTION Never mix chemicals.</p> <ul style="list-style-type: none"> • If chemicals come in contact with skin, flush with water immediately. • Refer to chemical container for correct application and safety procedures. • DO NOT add chemicals through the skimmer.

Continued on next page

Pool Setup & Maintenance Guide

How to Close your Pool (winterizing), Continued

Winterizing the Pump & Cartridge Filter

IF YOUR POOL IS EQUIPPED WITH A CARTRIDGE FILTER:
 Follow the steps below to winterize the Pump & Cartridge Filter.
NEVER allow moisture to freeze in the pool pump or pool filter.

Step	Action				
1	Turn off the pump.				
2	Put the ball valve in the “ closed position ”				
3	Open air release valve on top of filter.				
4	Remove the drain plug from pump (see diag. pg 7) and drain plug from filter (see diag. pg 8) and allow all water to drain from both				
5	<u>If your pool is recessed</u> - use a low pressure (below 5 PSI), high volume blower to purge the air from the skimmer and return hoses.				
6	<p>Drain the system piping. Make sure all the water is drained from the pump & filter.</p> <ul style="list-style-type: none"> • Gravity drain system as far as possible. • Loosen the union nuts (if used) to drain all water from the filter interior. Leave these nuts loose until the system is restarted. <p>NOTICE – The filter outlet piping will not empty through the filter drain. Make sure that the outlet piping has a separate drain for winterizing.</p> <table border="1" style="width: 100%; border-collapse: collapse;"> <thead> <tr> <th style="text-align: center;">If</th> <th style="text-align: center;">Then</th> </tr> </thead> <tbody> <tr> <td style="vertical-align: top;">Your pool is recessed (below the ground)</td> <td style="vertical-align: top;"> <p>You will not be able to gravity drain the lines:</p> <ul style="list-style-type: none"> • Using a wet/dry vacuum cleaner that is set to “blow” – blow air into the skimmer hose until air bubbles are coming from the skimmer. • While air is blowing , another person will need to be in the pool to attach the Aquador (see page 32) • Repeat above steps for return hose/return plug. </td> </tr> </tbody> </table>	If	Then	Your pool is recessed (below the ground)	<p>You will not be able to gravity drain the lines:</p> <ul style="list-style-type: none"> • Using a wet/dry vacuum cleaner that is set to “blow” – blow air into the skimmer hose until air bubbles are coming from the skimmer. • While air is blowing , another person will need to be in the pool to attach the Aquador (see page 32) • Repeat above steps for return hose/return plug.
If	Then				
Your pool is recessed (below the ground)	<p>You will not be able to gravity drain the lines:</p> <ul style="list-style-type: none"> • Using a wet/dry vacuum cleaner that is set to “blow” – blow air into the skimmer hose until air bubbles are coming from the skimmer. • While air is blowing , another person will need to be in the pool to attach the Aquador (see page 32) • Repeat above steps for return hose/return plug. 				
7	<p>Disassemble the filter (See Page 8).</p> <ul style="list-style-type: none"> • If the filter is equipped with an optional internal spring check valve (in the tank outlet), manually open the check valve to allow any water trapped in the tank to drain. 				
8	<p>Remove the filter cartridge module and store it in a warm, dry area.</p> <ul style="list-style-type: none"> • Cover the filter with plastic or tarpaulin to prevent water entrance and freezing. • Protect areas which retain water with non-toxic propylene glycol antifreeze (“RV antifreeze”). 				
9	Store drain plugs, eyeball, sleeve, and any other small parts in the pump strainer basket.				

Continued on next page

Pool Setup & Maintenance Guide

How to Close your Pool (winterizing), Continued

Winterizing the Pump & Sand Filter

IF YOUR POOL IS EQUIPPED WITH A SAND FILTER:
Follow the steps below to winterize the Pump & Sand Filter.
NEVER allow moisture to freeze in the pool pump or pool filter.

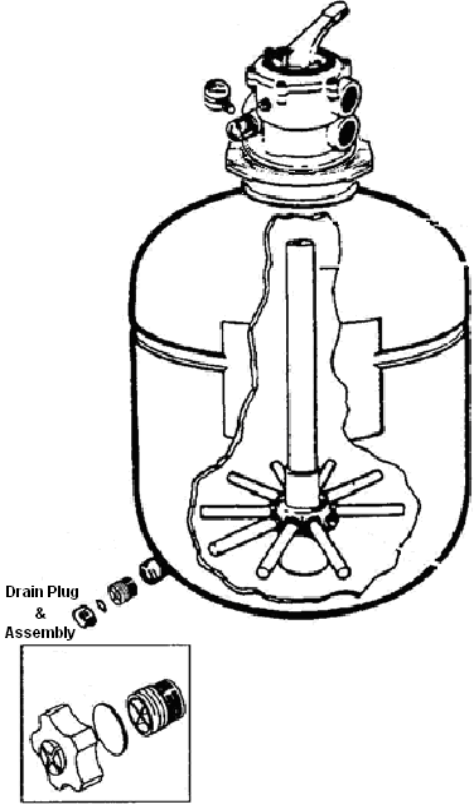
Step	Action
1	Turn off the pump.
2	Put the ball valve in the “closed position”
3	Turn valve switch to the “Winterize” position.
	<p>Remove the drain plug from pump (see diag. pg 7) and drain plug from filter and allow all water to drain from both.</p>  <p>The diagram shows a cross-section of a sand filter. A drain plug assembly is shown being removed from the bottom of the filter. The assembly consists of a cap, a plug, and a nut. A separate inset diagram shows the components of the drain plug assembly: a cap, a plug, and a nut.</p> <p>NOTICE - Only remove drain port cap, NOT the entire fitting for draining water from filter. Removing the entire fitting will allow sand to drain slowly. The filter will drain slowly. Leave the drain port cap off and store it during the time the system is shut down.</p>

Continued on next page

Pool Setup & Maintenance Guide

How to Close your Pool (winterizing), Continued

Step	Action						
4	Depress Vari-Flo control valve handle and rotate so as to set pointer on valve top between any two positions. This will allow water to drain from the valve. Leave valve in this "inactive" position.						
5	<u>If your pool is recessed or inground</u> - use a low pressure (below 5 PSI), high volume blower to purge the air from the skimmer and return hoses.						
6	<p>Drain the system piping. Make sure all the water is drained from the pump & filter.</p> <ul style="list-style-type: none"> • Gravity-drain system as far as possible. • Loosen the union nuts (if used) to drain all water from the filter interior. Leave these nuts loose until the system is restarted. <p>NOTICE – The filter outlet piping will not empty through the filter drain. Make sure that the outlet piping has a separate drain for winterizing.</p> <table border="1" style="width: 100%; border-collapse: collapse;"> <thead> <tr> <th style="text-align: center;">If</th> <th style="text-align: center;">Then</th> </tr> </thead> <tbody> <tr> <td style="vertical-align: top;">Your pool is recessed (below the ground)</td> <td style="vertical-align: top;"> <p>You will not be able to gravity drain the lines:</p> <ul style="list-style-type: none"> • Using a wet/dry vacuum cleaner that is set to “blow” – blow air into the skimmer hose until air bubbles are coming from the skimmer. • While air is blowing , another person will need to be in the pool to attach the Aquador (see page 32) • Repeat above steps for return hose/return plug. </td> </tr> <tr> <td style="vertical-align: top;">Pump can't be drained</td> <td style="vertical-align: top;">Non-toxic propylene glycol antifreeze will protect water-retaining areas up to -50°F.</td> </tr> </tbody> </table>	If	Then	Your pool is recessed (below the ground)	<p>You will not be able to gravity drain the lines:</p> <ul style="list-style-type: none"> • Using a wet/dry vacuum cleaner that is set to “blow” – blow air into the skimmer hose until air bubbles are coming from the skimmer. • While air is blowing , another person will need to be in the pool to attach the Aquador (see page 32) • Repeat above steps for return hose/return plug. 	Pump can't be drained	Non-toxic propylene glycol antifreeze will protect water-retaining areas up to -50°F.
If	Then						
Your pool is recessed (below the ground)	<p>You will not be able to gravity drain the lines:</p> <ul style="list-style-type: none"> • Using a wet/dry vacuum cleaner that is set to “blow” – blow air into the skimmer hose until air bubbles are coming from the skimmer. • While air is blowing , another person will need to be in the pool to attach the Aquador (see page 32) • Repeat above steps for return hose/return plug. 						
Pump can't be drained	Non-toxic propylene glycol antifreeze will protect water-retaining areas up to -50°F.						
7	Disassemble the filter (see page 9).						
8	<p>Remove the filter sand module with ARV attachment and store it in a warm, dry, weather-safe area.</p> <ul style="list-style-type: none"> • Cover the filter with plastic or tarpaulin to prevent water entrance and freezing if left outdoors. DO NOT wrap pump motor in plastic. Condensation could form inside, ruining it. • Protect areas which retain water with non-toxic propylene glycol antifreeze (“RV antifreeze”). <p>NOTICE - Do not use anti-freeze solutions except Propylene Glycol; as they are highly toxic and will damage the pump.</p>						
9	Store drain plugs, eyeball, sleeve, and any other small parts in the pump strainer basket.						

Continued on next page

Pool Setup & Maintenance Guide

How to Close your Pool (winterizing), Continued



Winterizing the FROG Cyclers

Follow the steps below to winterize the POOL FROG® Cycler.

Step	Action
1	Turn dial to Pac Removal and remove cap.
2	 <p>Unscrew knob in the back of POOL FROG® Cycler. Allow all water to drain.</p>
3	If FROG® <u>Bac Pac</u> still contains chlorine, wrap in plastic bag and store in shed or cool well-ventilated location away from children, pets, cars, motorcycles or anything metal that can rust, pit, etc. Make sure POOL FROG® Bac Pac is away from open flame.
4	Remove the FROG® <u>Mineral Reservoir</u> and discard in trash. Even if you hear spent minerals inside, it is no longer effective.
5	Replace the cap and knob loosely.

Complete Winterizing

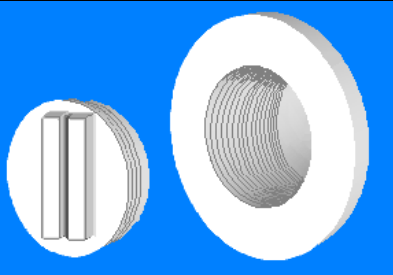
Follow the steps below to complete the winterization process.

Step	Action
1	 <p>Install the Winter return plug in to the Return port.</p> <p>NOTICE Make sure you have removed the sleeve prior to installing the winter plug.</p>
2	 <p>Install the Aquador as shown</p> <p>NOTICE The Aquador will fit very tightly and may take some effort to put on. You must make sure it is all the way on so that water does not leak from your skimmer.</p>

Continued on next page

Pool Setup & Maintenance Guide

How to Close your Pool (winterizing), Continued

Step	Action
3	<p>Turn the shutoff valve (1) on the PVC shutoff switch (2) so that it is in the closed position. Disconnect the PVC shutoff switch (2) from the ARV (3), and secure it so that it points straight up and so that the end is higher than the water level. This acts as an overflow, and must be SECURE.</p> <p>⚠ CAUTION DO NOT cap this line. This allows ice to expand as needed.</p> <p>⚠ CAUTION DO NOT cap the PVC atmosphere relief tube.</p>
4	<p>Disconnect the hose from the ball valve TO the skimmer and return hose FROM the Frog and let hang. All the water should drain from these lines. Leave them connected to your pool.</p>

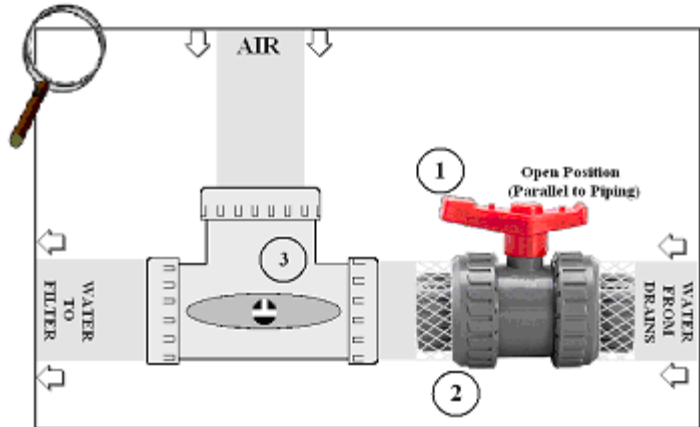
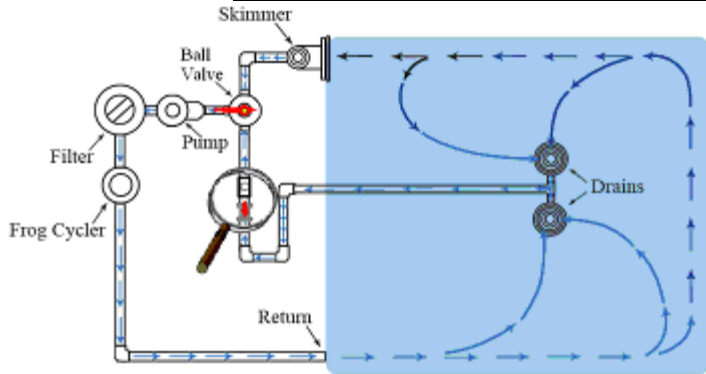
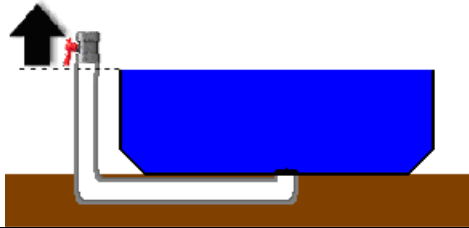

Continued on next page

Pool Setup & Maintenance Guide

How to Close your Pool (winterizing), Continued

Put on the Winter Cover

To put on your winter cover, follow the instructions provided from the manufacturer.

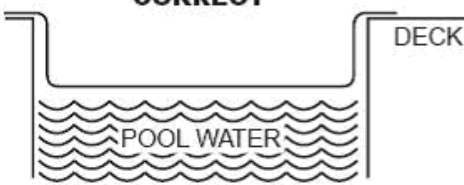
Tips For Round pools	
<u>NEVER COMPLETELY DRAIN A POOL!</u> <u>Pool water MUST be clear before closing your pool</u>	
All of the liquid chemicals should be poured around the inside perimeter of the pool and the granules should be broadcast across the surface <i>Some people like to dissolve the non-chlorine shock in a bucket of pool water and then add it to the perimeter</i>	
Pool covers are made to lie on top of the pool water; they are not made to stretch across the pool	
Pool water MUST be clear before closing your pool It couldn't hurt to get an extra bag or two of the non-chlorine shock and add it just for extra protection	

⚠ WARNING – DO NOT ALLOW LARGE QUANTITIES OF WATER, SNOW AND ICE TO BUILD UP ON THE SURFACE OF YOUR POOL COVER.

2” inches or less of water on your cover is permissible. Any more than this should be removed as too much water on the pool cover will cause excessive strain on the grommets and/or tarp tabs. You might consider getting a siphon pump to remove any standing water on your winter cover, as the winter drags on.

Excess weight will displace the water in the pool through the atmospheric release valve or by overflowing over the sides of the pool itself. If you are unable to remove the excess water, loosen the ropes or straps holding the cover to allow it to sag into pool water. This may result in some water loss through displacement but it will protect your cover and your pool until you can remove the excess water.

⚠ CAUTION – Failure to follow exact winterizing instructions could lead to irreparable damage to the your pool liner from falling ice in the spring.

Pool Setup & Maintenance Guide

How to Open your Pool (Spring opening)

Removing the Cover

Follow the steps below to remove the winter cover.

Step	Action
1	Prepare the winter cover for removal by clearing off all debris and water using a leaf skimmer and a cover pump.
2	Drain and remove the water sleeves.
3	Remove any tie down ropes.
4	Remove the cover, clean and dry it. Store cover for next season.

Reconnecting the Filter

Follow the steps below to open your pool at the beginning of each season.

Step	Action
1	Confirm that your pump shaft turns freely and connect pump to the system base.
2	Make sure to remove all parts stored in the pump strainer basket during winter storage and reinstall those stored parts.
3	Connect the pump to the filter tank.
4	Make sure O-rings on the Ball Valve are properly seated and in good operating condition.
5	Place the Ball valve in the “ skimmer only ” position and attach it to the hose leading from the floor drains. IMPORTANT: Keep the hose tied above the water line until the ball valve is securely attached to the hose.
6	Untie floor drain hose and bring the ball valve down and reattach it to the system base.
7	Reconnect the skimmer line to the ball valve.
8	Reconnect the ball valve to the pump
9	Connect the FROG to the return port of the Filter system.
10	Connect the return line to the FROG
11	Turn the Ball Valve to the “ closed position ”.
12	Remove the Aquador and the return plug. Replace sleeve and eyeball in return port.
13	Replace any displaced water so that water level is 3” – 4” above the bottom of the skimmer.
14	Install the ladder flanges. When the pool is full, install your in-pool ladder.
15	Place the basket inside skimmer and reattach the skimmer door.
16	The filter system is now reconnected and ready for start-up.

Pool Setup & Maintenance Guide

How to Open your Pool (Spring opening), Continued

Start up

Note: If you have a FROG® you will need a new Mineral Reservoir.

Note: Sand filters must be backwashed at the beginning of each season after setup. If your pool is equipped with a sand filter, follow the steps on pg 25.

Step	Action
1	Open air release valve on top of filter.
2	Put the Ball valve in the “ open position ”
3	Start pump to purge air from the system. *Note: If equipped with a sand filter, start pump with filter valve in the “ Filter ” position
4	Check the reading on the pressure gauge to ensure that your pressure has gone to its normal levels.
5	Place your hand in front of the return port inside your pool to confirm water is flowing into the pool. Your pool is now filtering water normally.
6	Set Frog dial back to normal operating level.
7	Shock the pool with chlorine to rid the water of all contaminants. ⚠ CAUTION DO NOT ADD SHOCK IN OR NEAR THE SKIMMER OR INTO THE FROG CYCLER DIRECTLY. This could cause damage to the equipment, discolor your pool surface and could risk a potential explosion.

Pool Setup & Maintenance Guide

Troubleshooting

Problem	Possible Solution
<ul style="list-style-type: none"> • If the pump is noisy or visibly leaking water. 	<ul style="list-style-type: none"> • Consult “Air in the System” section. • If problem cannot be found call 1 800 752-9000
<ul style="list-style-type: none"> • Motor will not run 	<ul style="list-style-type: none"> • Check the fuse or circuit breaker for an open circuit. If the circuit is equipped with a Ground Fault Interrupter, check the reset switch and then inspect the wiring connections for any short circuits or loose contact wires. • Your pump motor is equipped with Automatic Thermal Overload protection. The motor will automatically shut off before heat damage can occur, under normal conditions, due to an improper operating condition. The motor will restart when a safe heat level is reached. • If problem cannot be found call 1 800 752-9000
<ul style="list-style-type: none"> • Motor hums but will not run 	<ul style="list-style-type: none"> • Stones or debris may fall in to the housing below the strainer basket. This debris may have lodged between the impeller and the pump housing jamming the whole pump and motor assembly. • If problem cannot be found call 1 800 752-9000
<ul style="list-style-type: none"> • Noisy pump 	<ul style="list-style-type: none"> • Consult “Air in the System” section. • Blockage or restriction in suction or discharge lines. • Vibration due to improper mounting or loosening of bolts. • Foreign matter (such as a small stone) lodged between the impeller and the pump housing jamming the whole pump and motor assembly. • If problem cannot be found call 1 800 752-9000
<ul style="list-style-type: none"> • Low water flow returning to pool 	<ul style="list-style-type: none"> • Clean and rinse filter (see Cleaning the Filter section) • Consult “Air in the System” section. • Check for restrictions in baskets or intake lines. • If problem cannot be found call 1 800 752-9000
<ul style="list-style-type: none"> • Vacuum not working 	<ul style="list-style-type: none"> • Consult “Air in the System” section. • Inspect the vacuum hose for breaks or splits which may cause air leaks. Also check that the vacuum head or hose isn’t blocked or kinked. • Make sure the ball valve is set properly • If problem cannot be found call 1 800 752-9000

Pool Setup & Maintenance Guide

Troubleshooting

Problem	Possible Solution
<ul style="list-style-type: none"> • Air in the system 	<ul style="list-style-type: none"> • Check around the skimmer. If vacuum is hooked up, disengage vacuum and see if problem clears. If so look for improper seating of skim-vac attachment (vacuum plate) and elbow, cracked or blocked hose, or vacuum head. • Check that water is level is at proper level (1 inch below top of skimmer opening) • Clean the skimmer basket. Also, after the pump is turned off and restarted, the skimmer basket may occasionally become unseated and cause air to mix with the water. • Check the pump for a clogged strainer basket. If air bubbles are visible through the cover, problem is at the strainer housing or before it. • Check the strainer cover O-ring. Sand, dirt or other debris may be allowing air to enter. If this is the case, clean off O-ring and coat with O-ring lube, or replace O-ring if necessary. • Check hose connections for looseness or dripping water. • Check the ball valve for proper settings and leaks. • Changing the Ball Valve from “skimmer only” to “bottom drain only” may provide a clue to where the problem is. • Check for leaks around the multi-port valve, the base, the fittings and all hoses. • If problem cannot be found call 1 800 752-9000
<ul style="list-style-type: none"> • Liner coming out of track 	<ul style="list-style-type: none"> • Call 1 800 382-7946
<ul style="list-style-type: none"> • Pool leaks 	<p>NOTE – Normal daily water loss through evaporation can range from ¼” to ½” inch. Swimmers will also splash out water. Please take this into consideration when determining whether you have a leak or not.</p> <ul style="list-style-type: none"> • PLUMBING LEAKS – will usually result in air being drawn into the system. Consult “Air in the System” section. • LINER LEAKS – are usually indicated by a wet spot on the ground outside the pool in the general location of the leak • Call 1 800 752-9000